

MORSE TAPER ADAPTOR SHANK (TANGED) DIN 228-2 FORM D

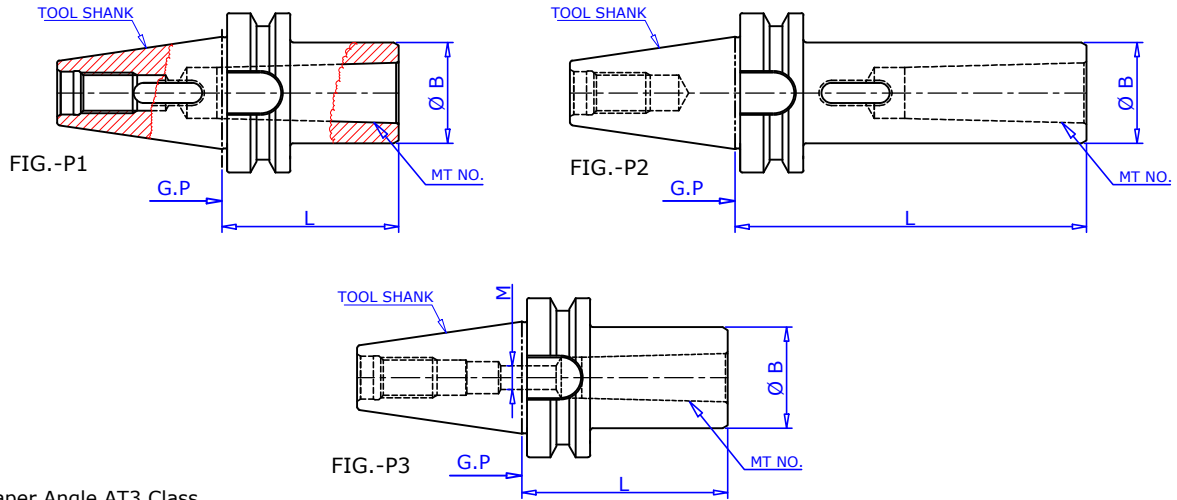

Taper Angle AT3 Class

Maximum runout of MOUNTING taper to INTERNAL taper 0.005mm

Balancing GRADE:- G6.3 /12,000 rev./min STD.

Designation	Tool Shank	MT. NO.	L	Ø B	FIG
BT 30 MTA 01 050 G.P	BT 30	MT-1	50	25	1
BT 30 MTA 01 110 G.P	BT 30	MT-1	110	25	1
BT 30 MTA 02 060 G.P	BT 30	MT-2	60	32	1
BT 30 MTA 02 120 G.P	BT 30	MT-2	120	32	2
BT 30 MTA 03 075 G.P	BT 30	MT-3	75	40	1
BT 30 MTA 03 140 G.P	BT 30	MT-3	140	40	2
BT 40 MTA 01 050 G.P	BT 40	MT-1	50	25	1
BT 40 MTA 01 115 G.P	BT 40	MT-1	115	25	1
BT 40 MTA 02 050 G.P	BT 40	MT-2	50	32	1
BT 40 MTA 02 125 G.P	BT 40	MT-2	125	32	2
BT 40 MTA 03 070 G.P	BT 40	MT-3	70	40	1
BT 40 MTA 03 140 G.P	BT 40	MT-3	140	40	2
BT 40 MTA 04 095 G.P	BT 40	MT-4	95	48	1
BT 50 MTA 01 050 G.P	BT 50	MT-1	50	25	1
BT 50 MTA 01 120 G.P	BT 50	MT-1	120	25	2
BT 50 MTA 02 060 G.P	BT 50	MT-2	60	32	1
BT 50 MTA 02 140 G.P	BT 50	MT-2	140	32	2
BT 50 MTA 03 065 G.P	BT 50	MT-3	65	40	1
BT 50 MTA 03 150 G.P	BT 50	MT-3	150	40	2
BT 50 MTA 04 095 G.P	BT 50	MT-4	95	48	1
BT 50 MTA 04 180 G.P	BT 50	MT-4	180	48	2
BT 50 MTA 05 120 G.P	BT 50	MT-5	120	63	1
BT 50 MTA 05 220 G.P	BT 50	MT-5	220	163	1

Ordering Example :- BT40 MTA 2 050G.P - 2 Nos.

HOLDER WITH MORSE TAPER SHANK (THREADED END)

Designation	Tool Shank	MT. NO.	M	L	B Ø	FIG
BT 40 MTA 02 050 G.P	BT 40	MT-2	M 10	50	32	3
BT 50 MTA 02 060 G.P	BT 50	MT-2	M 10	60	32	3
BT 50 MTA 03 065 G.P	BT 50	MT-3	M 12	65	40	3
BT 50 MTA 04 095 G.P	BT 50	MT-4	M 16	95	48	3

Ordering Example :- BT40 MTA 02 050 G.P - 2 Nos.

All Details are subject to change without notice.